

IMMERSION THERMOCOUPLES

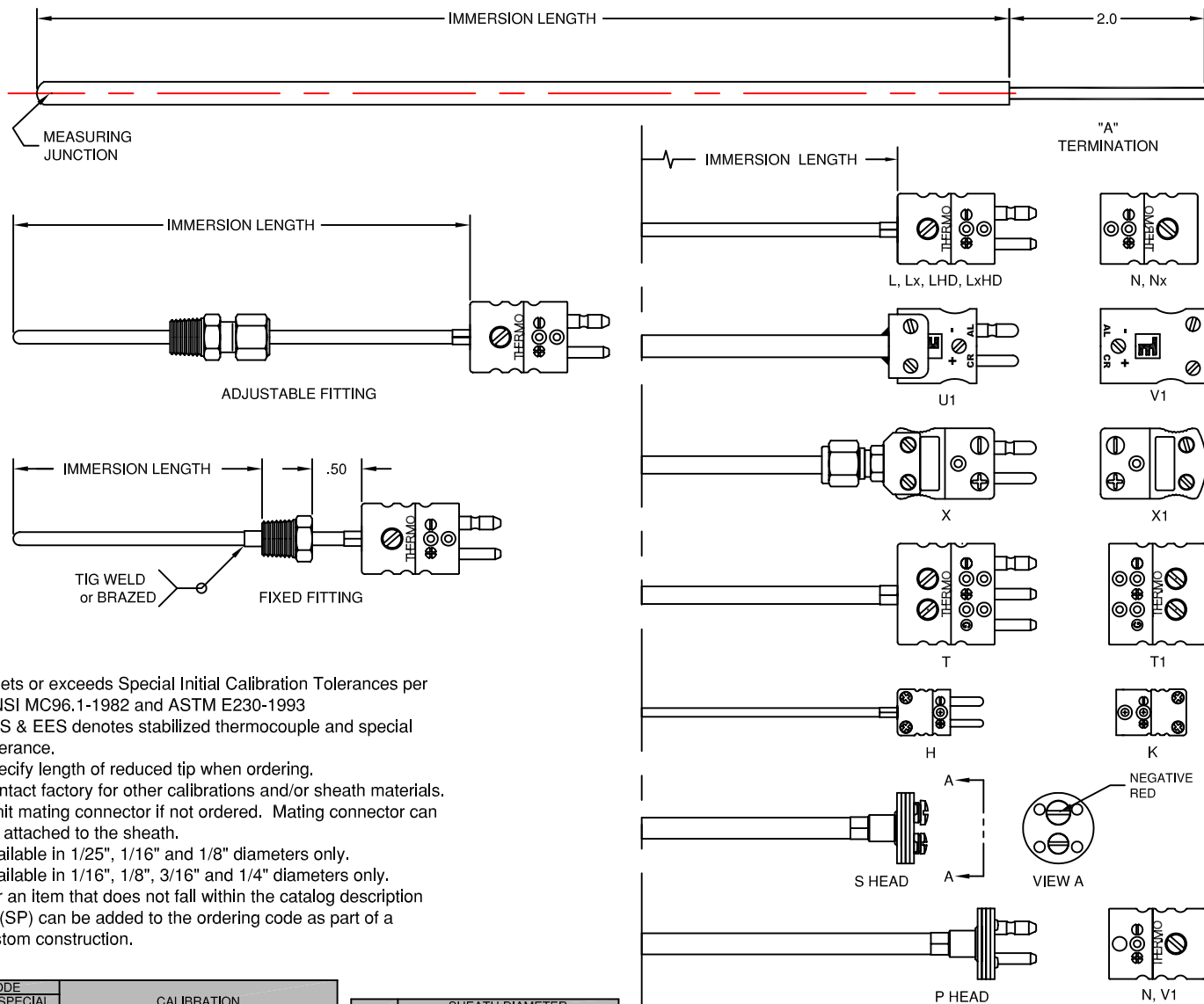

- Notes:**
- (1) Meets or exceeds Special Initial Calibration Tolerances per ANSI MC96.1-1982 and ASTM E230-1993
 - (2) KKS & EES denotes stabilized thermocouple and special tolerance.
 - (3) Specify length of reduced tip when ordering.
 - (4) Contact factory for other calibrations and/or sheath materials.
 - (5) Omit mating connector if not ordered. Mating connector can be attached to the sheath.
 - (6) Available in 1/25", 1/16" and 1/8" diameters only.
 - (7) Available in 1/16", 1/8", 3/16" and 1/4" diameters only.
 - (8) For an item that does not fall within the catalog description an (SP) can be added to the ordering code as part of a custom construction.

CODE		CALIBRATION
STD.	SPECIAL (NOTE 1)	
J	JJ	IRON(+) vs CONSTANTAN(-)
K	KK	CHROMEL(+) vs ALUMEL(-)
T	TT	COPPER(+) vs CONSTANTAN(-)
E	EE	CHROMEL(+) vs CONSTANTAN(-)
N	NN	NICROSIL(+) vs NISIL(-)
	KKS	CHROMEL(+) vs ALUMEL(-) (NOTE 2)
	EES	CHROMEL(+) vs CONSTANTAN(-) (NOTE 2)

CODE	SHEATH DIAMETER		
	FRACTION	DECIMAL	METRIC
125	1/25"	.040	1.1mm
116	1/16"	.063	1.6mm
18	1/8"	.125	3.2mm
316	3/16"	.187	4.8mm
14	1/4"	.250	6.4mm
516	5/16"	.313	8.0mm
38	3/8"	.375	9.5mm

CODE	MEASURING JUNCTION
G	GROUNDING
U	UNGROUNDING
RG	REDUCED GRD. (NOTE 3)
RU	REDUCED UNGRD. (NOTE 3)
E	EXPOSED LOOP

CODE	SHEATH MATERIAL	
	MATERIAL	STD. CALIBRATIONS (NOTE 4)
304	304 STN. STL.	J, K, T
316	316 STN. STL.	J, K, T, E, N
310	310 STN. STL.	J, K, E
1600	INCONEL 600	K, N, KKS(NOTE 2), EES(NOTE 2)

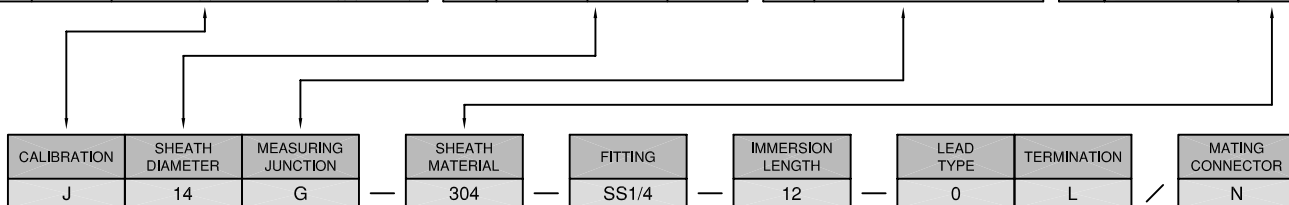

CODE	FITTING	CODE	THREAD SIZE
BR	ADJUSTABLE BRASS, BRASS INSERT	1/8	1/8"NPT
BRT	READJUSTABLE BRASS, TEFLON INSERT	1/4	1/4"NPT
SS	ADJUSTABLE STN. STL., STN. STL. INSERT	1/2	1/2"NPT
SST	READJUSTABLE STN. STL., TEFLON INSERT		
SSL	READJUSTABLE STN. STL., LAVA INSERT		
FX	FIXED STN. STL., ATTACHED TO SHEATH		
0	FITTING NOT REQUIRED		

CODE	IMMERSION LENGTH (IN INCHES)

CODE	TERMINATION	MATING CONN. (NOTE 5)	
		CODE	TEMPERATURE LIMIT
A	BARE ENDS	N	390°F(200°C)
L	STANDARD SIZE PLUG	N	390°F(200°C)
LHD	STANDARD SIZE SOLID PIN PLUG	Nx	660°F(320°C)
Lx	EXTENDED LIMITS PLUG	Nx	660°F(320°C)
LxHD	EXTENDED LIMITS SOLID PIN PLUG	V1	300°F(150°C)
U1	IMPACT RESISTANT PHENOLIC PLUG	X1	1000°F(538°C)
X	ULTRA-TEMP PLUG	T1	390°F(200°C)
T	THREE PIN PLUG	K	390°F(200°C)
H	MINIATURE PLUG (NOTE 6)	N, V1	350°F(177°C)
S	COOLANT HEAD (NOTE 7)		
P	COOLANT PLUG (NOTE 7)		



TEMPERATURE MEASUREMENT DESIGNER'S GUIDE
WWW.THERMO-ELECTRIC-DIRECT.COM

SECTION IMTC IMMERSION THERMOCOUPLES with CONNECTORS SINGLE CONSTRUCTION

The information contained herein shall be considered the sole property of Thermo Electric Company, Inc. The recipient thereof agrees not to disclose or reproduce said information to parties outside the recipient's organization without the written permission of Thermo Electric.

Doc. No.: TE-CO010109-IMTC-010